

# 17652

17654, 17750, 17751, 17752, 17753

## STONE COATED STEEL ROOF HOOK

FOR SIDE MOUNT RAILS

FOR ROOF PANELS INSTALLED DIRECT-TO-DECK WITH NO BATTEN SYSTEM.



# TABLE OF CONTENTS

3

## SPEC SHEET

QTY & MEASUREMENT INFORMATION

---

4

## UL CERTIFICATION

PROOF OF UL CERTIFICATION

---

6

## INSTALLATION INSTRUCTIONS

STEP-BY-STEP-INSTALLATION GUIDE

---

7

## BUILDING CODE LETTER

REGARDING STAMP DATES

---

8

## ENGINEERING REPORT

UPLIFT & LATERAL LOAD TEST

---

# SPEC SHEET

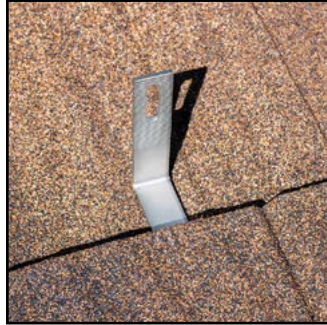

| Part # | Box Quantity          | Screw Size |
|--------|-----------------------|------------|
| 17652  | 50 Hooks              | N/A        |
| 17654  | 1 Hook                | N/A        |
| 17750  | 50 Hooks + 100 Screws | 1/4 x 3"   |
| 17751  | 1 Hook + 2 Screws     | 1/4 x 3"   |
| 17752  | 50 Hooks + 100 Screws | 5/16 x 3"  |
| 17753  | 1 Hook + 2 Screws     | 5/16 x 3"  |

Hook Material: Stainless Steel (SUS304)  
Hook Finish: Sandblasted

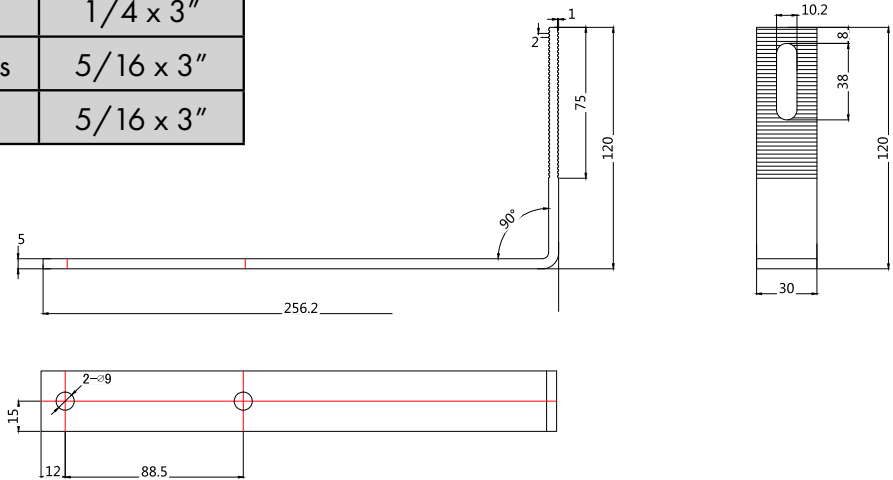

|             | M    | C    |
|-------------|------|------|
| <3          | ±0.1 | ±0.2 |
| <3-6        | ±0.1 | ±0.3 |
| <6-30       | ±0.2 | ±0.5 |
| <30-120     | ±0.3 | ±0.8 |
| <120-400    | ±0.5 | ±1.2 |
| <400.0-1000 | ±0.8 | ±2   |
| <1000-2000  | ±1.2 | ±3   |
| <2000-1000  | ±2   | ±4   |

|        |  |  |  |            |  |                    |  |        |  |        |  |        |  |
|--------|--|--|--|------------|--|--------------------|--|--------|--|--------|--|--------|--|
| Item   |  |  |  | Mark       |  | Verify the Content |  | Sign   |  | Date   |  | A4     |  |
| Title  |  |  |  | Part No    |  | Material           |  | Weight |  | Deg No |  | Scale  |  |
| App' D |  |  |  | Chk' D     |  | Proofread          |  | Design |  | SUS304 |  | 0.45KG |  |
| Sign   |  |  |  | MW         |  | MW                 |  | MW     |  | Qty    |  | 1PCS   |  |
| Date   |  |  |  | 03/31/2021 |  |                    |  |        |  | View   |  |        |  |

## CERTIFICATE OF COMPLIANCE

**Certificate Number** E493748  
**Report Reference** E493748-20170817  
**Date** 2023-April-07

**Issued to:** QuickBOLT a Division of Quickscrews International Corp  
5830 Las Positas Rd  
Livermore CA, 94551 US

**This is to certify that  
representative samples of**

MOUNTING SYSTEMS, MOUNTING DEVICES, CLAMPING  
DEVICES AND GROUND LUGS FOR USE WITH  
PHOTOVOLTAIC MODULES AND PANELS - COMPONENT

See Addendum Page for Product Designation(s).

Have been evaluated by UL in accordance with the component requirements in the Standard(s) indicated on this Certificate. UL Recognized components are incomplete in certain constructional features or restricted in performance capabilities and are intended for installation in complete equipment submitted for investigation to UL LLC.

**Standard(s) for Safety:** UL 2703, Mounting systems, mounting devices, clamping/retention devices, and ground lugs for use with flat-plate photovoltaic modules and panels-.

**Additional Information:** See the UL Online Certifications Directory at <https://iq.ulprospector.com> for additional information

This Certificate of Compliance indicates that representative samples of the product described in the certification report have met the requirements for UL certification. It does not provide authorization to apply the UL Recognized Component Mark. Only the Authorization Page that references the Follow-Up Services Procedure for ongoing surveillance provides authorization to apply the UL Mark.

Only those products bearing the UL Recognized Component Mark should be considered as being UL Certified and covered under UL's Follow-Up Services.

Look for the UL Recognized Component Mark on the product.



Deborah Jennings-Conner, VP Regulatory Services

UL LLC

Any information and documentation involving UL Mark services are provided on behalf of UL LLC (UL) or any authorized licensee of UL. For questions, please contact a local UL Customer Service Representative at <http://ul.com/about/locations/>



# CERTIFICATE OF COMPLIANCE

**Certificate Number** E493748  
**Report Reference** E493748-20170817  
**Date** 2023-April-07

This is to certify that representative samples of the product as specified on this certificate were tested according to the current UL requirements

**Models:**

USR – Component, Roof Mounting Hook Units, Models 15891 15893 15987 16000 16317 16318  
16319 16320 16988 16990 16991 16993 17508 17509 17510 17511 17512 17513 17514 17515  
17516 17517 17518 17519 17520 17521 17522 17523 17524 17525 17526 17527 17536 17537  
17538 17539 17540 17541 17542 17543 17544 17545 17546 17547 17548 17549 17550 17551  
17552 17553 17554 17555 17556 17558 17559 17560 17566 17567 17568 17569 17570 17571  
17572 17573 17574 17575 17576 17577 17578 17579 17580 17585 17586 17587 17588 17589  
17592 17596 17597 17598 17599 17600 17601 17606 17607 17608 17609 17610 17611 17612  
17613 17614 17615 17616 17617 17618 17620 17621 17622 17623 17624 17625 17626 17627  
17628 17629 17630 17631 17632 17633 17636 17637 17638 17639 17640 17641 17642 17643  
17646 17647 17648 17649 17650 17651 17652 17653 17654 17659 17664 17667 17669 17670  
17671 17672 17673 17678 17679 17680 17681 17686 17687 17688 17689 17700 17701 17702  
17703 17704 17705 17706 17707 17708 17709 17710 17711 17712 17717 17718 17750 17751  
17752 17753 17759 15891-10 15891BLK-10 15987A 15987B 17667SS 17672SS 17680SS  
17688SS 17713SS 17720 17721SS 17723 17724SS 17726 17727SS 17729 17730SS 15894SS  
15891SS 15987BSS 17660 17661 17662 17663 17747 17748



Deborah Jennings-Conner, VP Regulatory Services

UL LLC

Any information and documentation involving UL Mark services are provided on behalf of UL LLC (UL) or any authorized licensee of UL. For questions, please contact a local UL Customer Service Representative at <http://ul.com/aboutul/locations/>



# INSTALL INSTRUCTIONS

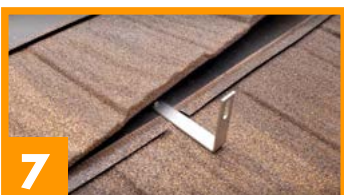

## RECOMMENDED MATERIALS

- Rafter locator
- Chalk or crayon
- 3/16" Drill Bit
- Aviation or Tin Snips
- Sealant

## INSTALLATION INSTRUCTIONS

1. Locate and mark the rafters
2. Snip panel's Bottom Clip Lock return enough for hook to sit flush
3. Snip or bend off the cut piece of metal
4. Place the Hook and predrill two holes with the 3/16" Drill Bit
5. Remove the Hook, clear the debris, and fill the predrilled holes with sealant
6. Place and mount the Hook using the Solar Screws
7. Place the Stone Coated Steel Panel back over the installation area and lock into place by sliding the nose of the panel onto the clip joint

## IF USING GALVA FLASHING

1. Make a cut in the paper
2. Apply sealant to the underside of the Galva Flashing
3. Slide the Flashing underneath the paper or nail down edges
4. Cover the edges of the Galva Flashing with sealant



**IMPORTANT:** "Direct-to-deck" describes the roof panel installation method. This is not a deck-mount hook.

# BUILDING CODE LETTER



March 22<sup>nd</sup>, 2023

To whom this may concern,

QuickBOLT is committed to excellence. The parts tested are durable goods, meaning the material composition and detailed specifications of the parts do not change. Therefore, all stamps are current. Any part tested will have the same results no matter what year the tests are performed. All testing and reports are current and valid with 2022 CBC standards.

SolarRoofHook is the previous name of QuickBOLT. Any test result referencing SolarRoofHook is referring to a QuickBOLT product.

All our parts were tested by a third-party test facility, in possession of a current engineering license for the state where the tests were performed for the following.

1. Uplift test
2. Downward load test
3. Lateral Test – Asphalt Mounts, and Metal Mounts only
4. ASTM E2440 and ASTM E330 Waterproof Tests - QuickBOLT only

The following is an excerpt from:

CALIFORNIA BOARD FOR PROFESSIONAL ENGINEERS AND LAND SURVEYORS  
guide to Engineering & Land Surveying for City and County Officials  
Page 12, Line 27

**27. If the license has expired between the time the engineering documents were prepared and the time when the local agency's review is performed, do the documents need to be re-sealed by a licensee with a current license? (B&P Code §§ 6733, 6735, 6735.3, 6735.4)**

**As long as the license was current at the time the engineering documents were prepared, the documents do not need to be re-sealed prior to review by the local agency. However, any changes (updates or modifications) to the documents that are made following the review by the local agency would have to be prepared by a licensed engineer with a current license and those changes would have to be signed and sealed.**

We trust the information provided will resolve any request for the test reports submitted to have a stamp from the current year.

Regards,

Rick Gentry  
Executive Vice President

# ENGINEERING REPORT



APPLIED MATERIALS & ENGINEERING, INC.

980 41<sup>st</sup> Street  
Oakland, CA 94608

Tel: (510) 420-8190  
FAX: (510) 420-8186  
e-mail: [info@appmateng.com](mailto:info@appmateng.com)

April 24, 2023

Mr. Rick Gentry  
**Quickscrews International**  
5830 Las Posita Road  
Livermore, CA 94551

Project No.: 1230212C

Email: [RGentry@quickscrews.com](mailto:RGentry@quickscrews.com)

Subject: PV Mount SCS Straight 90 No-Batten Hook 304 50/CS Laboratory Load Testing

Dear Mr. Gentry:

As requested, Applied Materials & Engineering, Inc. (AME) has completed load-testing the PV Mount SCS Straight 90 No-Batten Hook 304 50/CS. The purpose of our testing was to evaluate the tensile (uplift) and shear load capacity of PV Mount SCS Straight 90 No-Batten Hook 304 50/CS attached to a 2"x6" rafter through 1/2" OSB using two (2) 5/16"Øx2-1/2" lag screws.

## **SAMPLE DESCRIPTION**

Six SCS Straight 90 No-Batten Hook 304 50/CS samples were delivered to our laboratory on March 22, 2023. Mockup configuration consisted of three 12" long rafters at 6" o.c., screwed to 1/2" OSB. The SCS Straight 90 No-Batten Hook 304 50/CS is attached through the OSB into the middle rafter using two (2) 5/16"Øx2-1/2" lag screws. Drawings of the sample are provided in Appendix A.

## **TEST PROCEDURES & RESULTS**

### **1. Tensile (Uplift) Load Test**

A total of three tests were conducted for tensile (uplift) load capacity on April 21, 2023 using a United Universal testing machine. Samples were rigidly attached to the testing machine and an uplift (tensile) load was applied to the mount. The samples were loaded in tension at a constant rate of axial deformation of 0.1 in./min. without shock until failure occurred; displacement at maximum load was recorded.

Based on the above testing, the average maximum uplift load of the SCS Straight 90 No-Batten Hook 304 50/CS attached to a 2"x6" rafter through 1/2" OSB using two (2) 5/16"Øx2-1/2" lag screws was determined to be 1689 lbf; at 1/8" displacement, the average uplift load was determined to be 56 lbf. Detailed results are provided in Table I and Figure 1. Test setup and mode of failure are provided in Appendix B.

Mr. Rick Gentry

**Quickscrews International**

PV Mount SCS Straight 90 No-Batten Hook 304 50/CS Laboratory Load Testing

April 24, 2023

2. Shear (Lateral) Load Test Parallel to Rafter

A total of three tests were conducted for shear load capacity on April 22, 2023 using a United Universal testing machine. Samples were rigidly attached to the testing machine and a shear load (parallel to the rafter) was applied to the hook. The samples were loaded in compression at a constant rate of axial deformation of 0.1 in. /min. without shock until failure occurred; displacement at maximum load was recorded.

Based on the above testing, the average maximum shear load of the SCS Straight 90 No-Batten Hook 304 50/CS attached to a 2"x6" rafter through 1/2" OSB using two (2) 5/16"Øx2-1/2" lag screws was determined to be 3109 lbf; at 1/8" displacement, the average shear load was determined to be 91 lbf. Detailed results are provided in Table II and Figure 2. Test setup and mode of failure are provided in Appendix B.

Respectfully Submitted,

**APPLIED MATERIALS & ENGINEERING, INC.**

Armen Tajirian, Ph.D., P.E.  
Principal

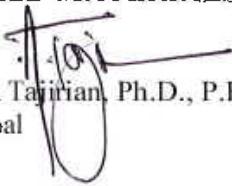

**TABLE I**

**TENSILE (UPLIFT) LOAD TEST RESULTS**

**PV MOUNT SCS STRAIGHT 90 NO-BATTEN HOOK 304 50/CS LABORATORY LOAD TESTING**

**PROJECT NUMBER 1230212C**

| <b>Test No.</b> | <b>Maximum Uplift Load (lb)</b> | <b>Load at 1/8" Displacement (lb)</b> | <b>Displacement At Maximum Load (in.)</b> | <b>Mode of Failure</b> |
|-----------------|---------------------------------|---------------------------------------|---|------------------------|
| 8570 U-1        | 1624                            | 46                                    | 5.2                                       | Bolt Break             |
| 8571 U-2        | 1604                            | 51                                    | 5.0                                       | Bolt Break             |
| 8572 U-3        | 1840                            | 72                                    | 5.2                                       | Bolt Break             |
| <b>Average</b>  | <b>1689</b>                     | <b>56</b>                             | <b>5.1</b>                                | <b>..</b>              |

## TENSILE (UPLIFT) LOAD-DISPLACEMENT CURVES



Report No 1731      Tensile Test - XHD Control

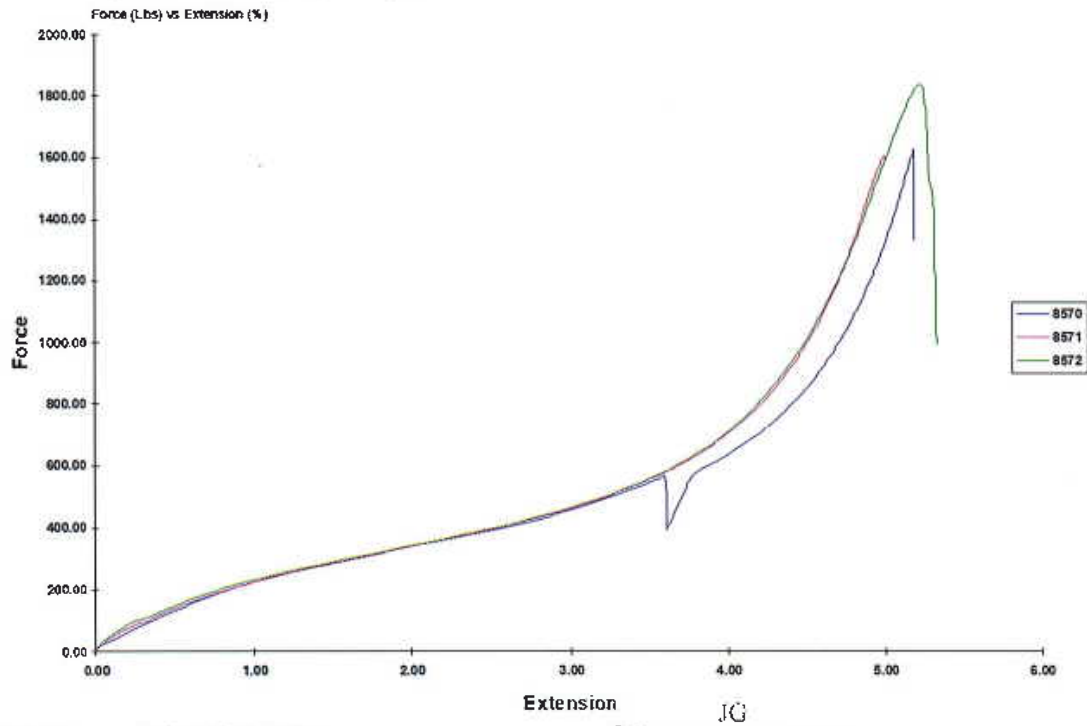

Template 7      Testing Machine SMART Teste

Apr 24, 2023

Applied Materials & Engineering    980 41st. Street    Oakland, CA 94642    TEL    FAX

Figure 1. Test 8570, 8571, 8572 tensile (uplift) load vs. displacement curve.

**TABLE II**

**SHEAR LOAD TEST RESULTS**

**PV MOUNT SCS STRAIGHT 90 NO-BATTEN HOOK 304 50/CS LABORATORY LOAD TESTING**

**PROJECT NUMBER 1230212C**

| <b>Test No.</b> | <b>Maximum Shear Load (lb)</b> | <b>Load At 1/8" Displacement (lb)</b> | <b>Displacement At Maximum Load (in.)</b> | <b>Mode of Failure</b> |
|-----------------|--------------------------------|---------------------------------------|---|------------------------|
| 8674 S-1        | 3835                           | 49                                    | 4.1                                       | Hook Straightening     |
| 8675 S-2        | 3661                           | 47                                    | 3.7                                       | Hook Straightening     |
| 8676 S-3        | 1830                           | 177                                   | 3.6                                       | Hook Straightening     |
| <b>Average</b>  | <b>3109</b>                    | <b>91</b>                             | <b>3.8</b>                                | <b>..</b>              |

## SHEAR LOAD-DISPLACEMENT CURVES



Report No 1766      Compressive Test - XHD Control

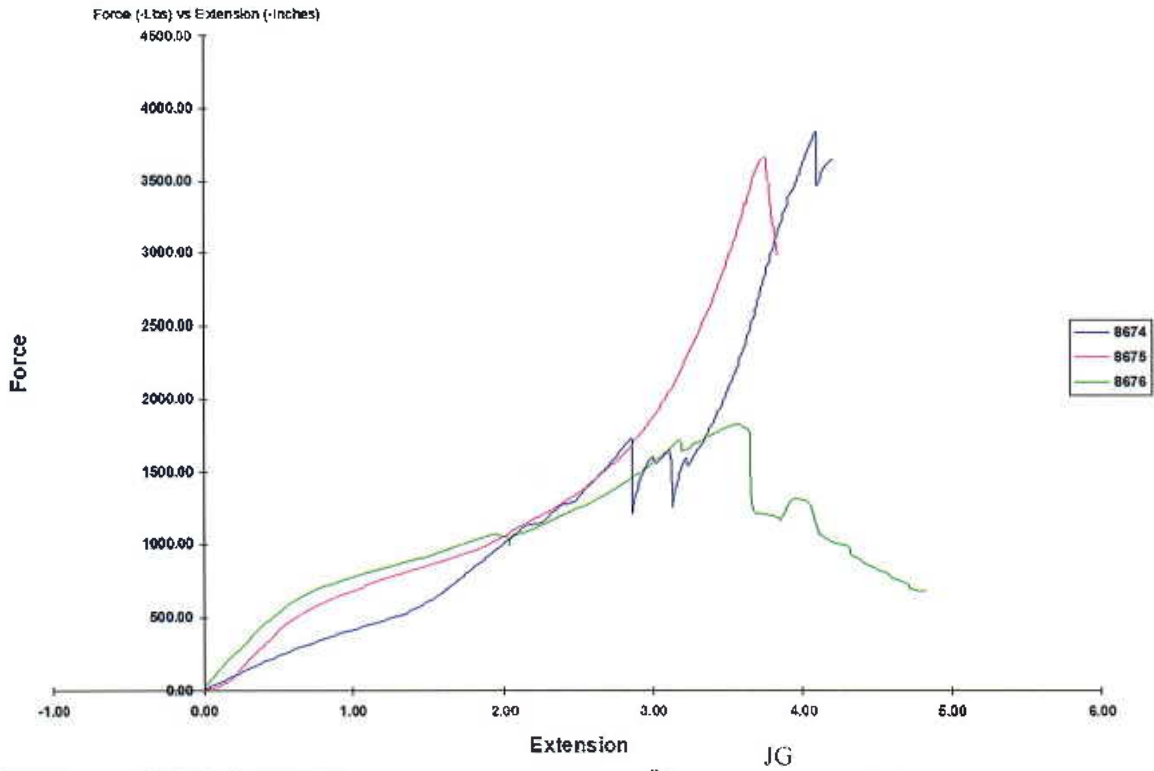

Template 9      Testing Machine SMART Teste      By: JG  
Apr 24, 2023      Applied Materials & Engineering      980 41st. Street      Oakland, CA 94542      TEL      FAX

**Figure 2. Test 8574, 8575, 8576 shear load vs. displacement curve. At ~3 inches displacement, metal hook began to straighten. In test 8576, loading was stopped once straightening began to occur.**

## REFERENCES

- AC13-2010, "*Acceptance Criteria for Joist Hangers and Similar Devices*", ICC Evaluation Service.
- ASTM D1761-2006, "*Standard Test Methods for Mechanical Fasteners in Wood*", ASTM International.
- ASTM D2395-2007, "*Standard Test Method for Specific Gravity of Wood and Wood-Based Materials*", ASTM International.

## **APPENDIX B**

**TENSILE LOAD TEST SETUP**

**PV MOUNT SCS STRAIGHT 90 NO-BATTEN HOOK 304 50/CS**  
**LABORATORY LOAD TESTING**

**PROJECT NUMBER 1230212C**

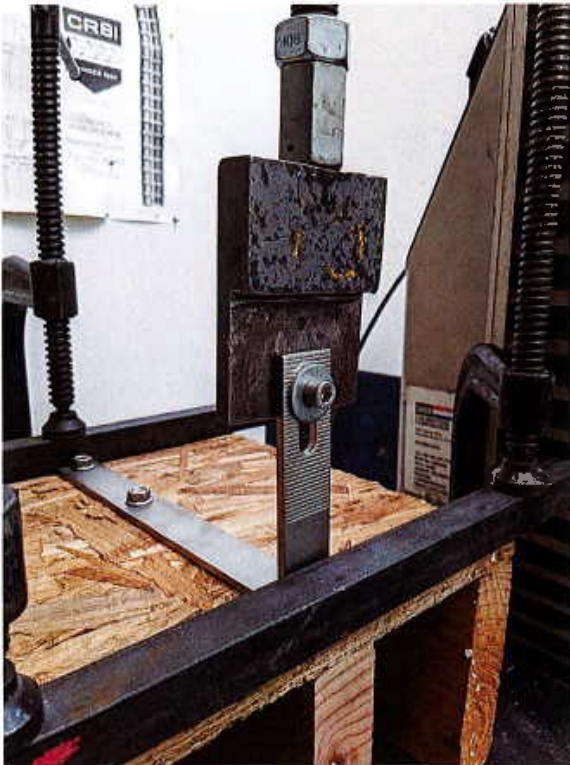

**Figure 3a. Test set up.**



**Figure 3b. Typical failure mode.**

**SHEAR LOAD TEST SETUP**

**PV MOUNT SCS STRAIGHT 90 NO-BATTEN HOOK 304 50/CS**  
**LABORATORY LOAD TESTING**

**PROJECT NUMBER 1230212C**



**Figure 2a. Test set up.**



**Figure 2b. Typical failure mode.**